

XO-4 B1 Tinderbox

10/01/12

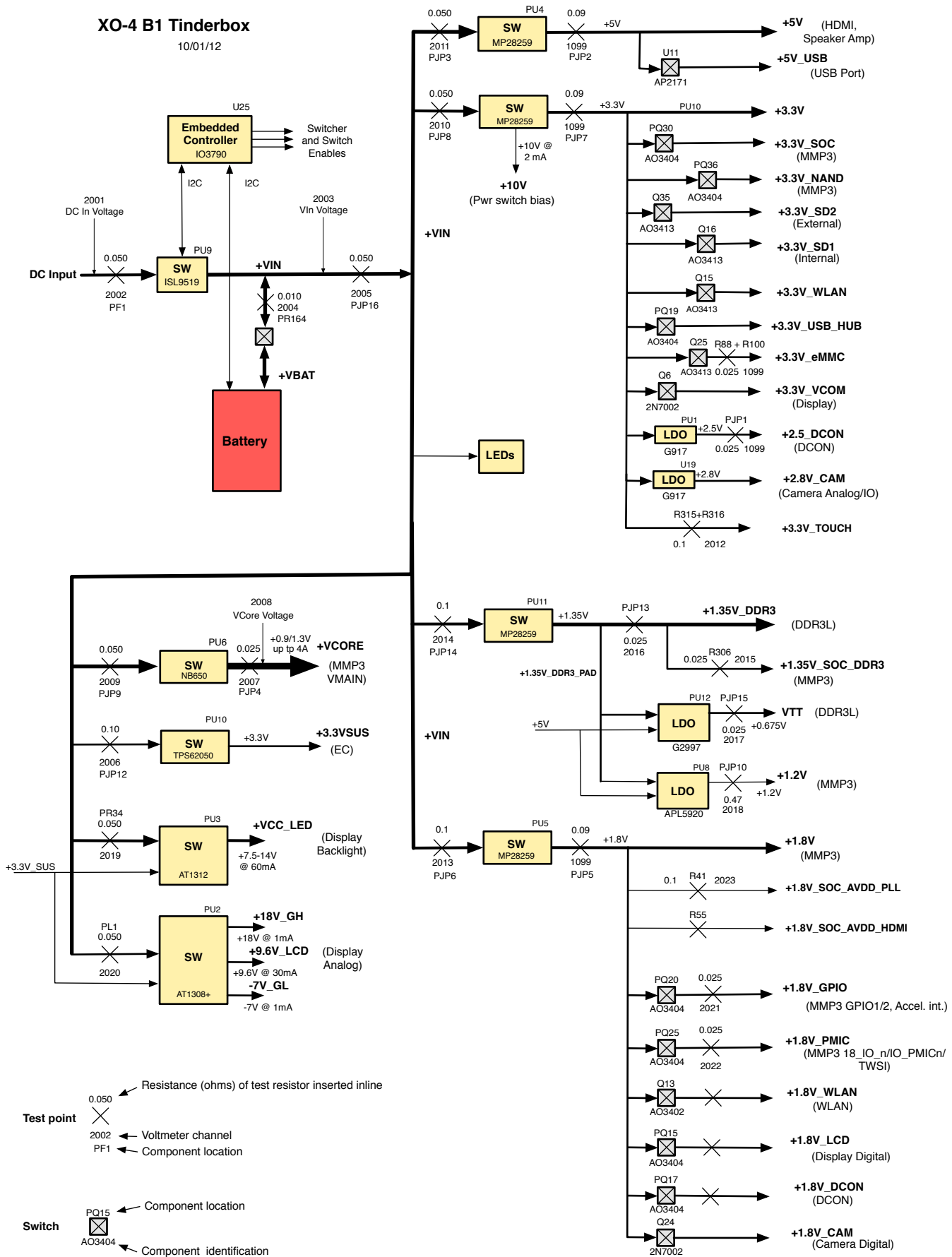

Resistance (ohms) of test resistor inserted inline
 Test point
 0.050
 2002 ← Voltmeter channel
 PF1 ← Component location

Switch
 PQ15 ← Component location
 AO3404 ← Component identification